

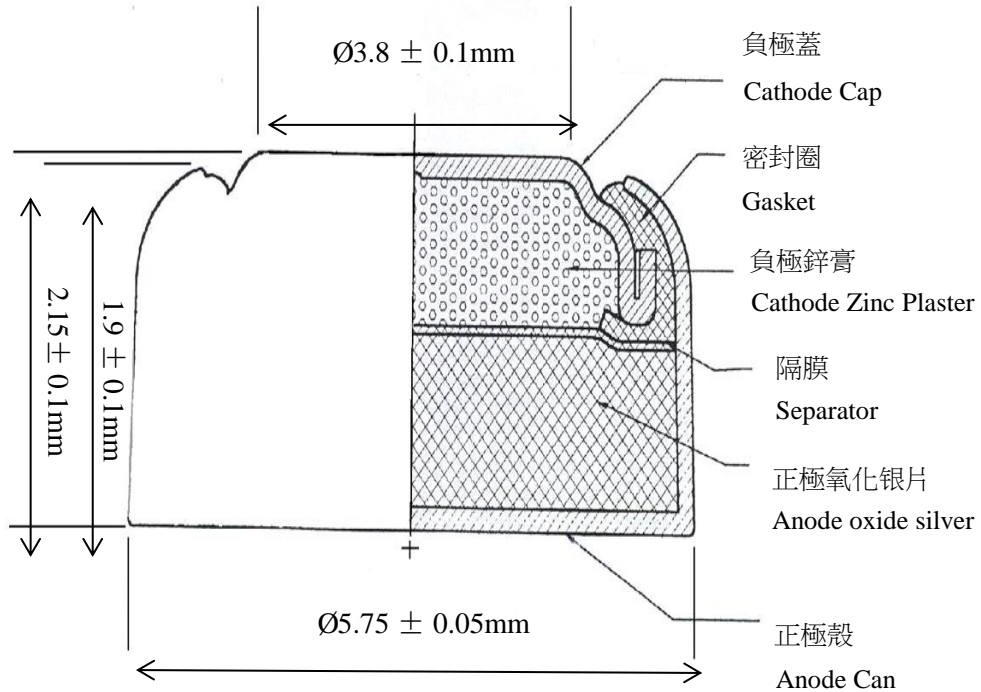

# WAMA ELECTRONICS TECHNOLOGY CO.,LTD

## SR521SW,379 BUTTON CELL

### DIMENSIONS:



**NOMINAL VOLTAGE : 1.55 VOLT**

**APPROX. SERVICE CAPACITY : 10 mAh**

**APPROX. WEIGHT : 0.21 g**

**RATED AT 7.5K $\Omega$  LOAD TESTED AT 21°C WITHIN 12 MONTHS OF MANUFACTURE.**

**SYSTEM : ZINC /MANGANESE DIOXIDE.**

### ESTIMATED AVERAGE HOURS SERVICE AT 21 °C

