

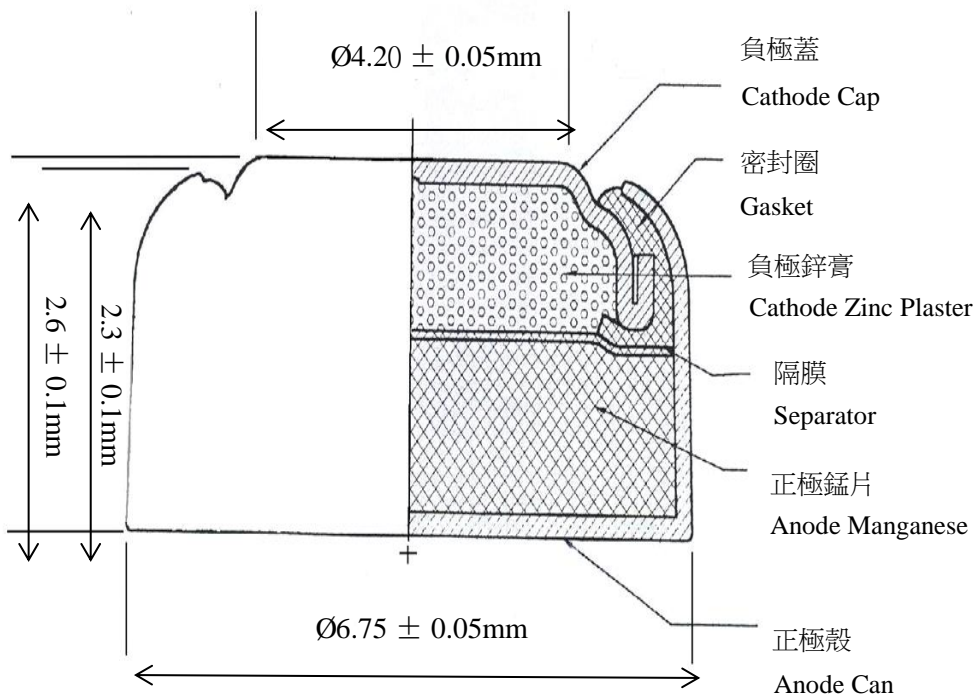

WAMA ELECTRONICS TECHNOLOGY CO.,LTD

AG4,LR626,377 BUTTON CELL

DIMENSIONS:



NOMINAL VOLTAGE : 1.5 VOLT

APPROX. SERVICE CAPACITY : 22 mAh

APPROX. WEIGHT : 0.35 g

RATED AT 7.5K Ω LOAD TESTED AT 21°C WITHIN 30 DAYS OF MANUFACTURE.

SYSTEM : ZINC /MANGANESE DIOXIDE.

ESTIMATED AVERAGE HOURS SERVICE AT 21 °C

